

**FIRESTONE RUBBERGARD R.M.A. ROOFING SYSTEM
APPLICATION GUIDE**

December 1, 2011

Table of Contents

2.02 JOB SITE CONSIDERATIONS (CAUTION AND WARNINGS) 3

2.04 WOOD NAILER LOCATION AND INSTALLATION 5

2.05 AIR OR VAPOR BARRIER INSTALLATION 6

2.06 INSULATION INSTALLATION 7

2.07 MEMBRANE SECUREMENT AND INSTALLATION (QSRMA ATTACHMENT) 7

2.09 ADDITIONAL MEMBRANE SECUREMENT AND BASE TIE-IN FLASHING 10

2.10 FLASHING - PENETRATIONS 10

2.11 FLASHING - WALLS, PARAPETS, MECHANICAL EQUIPMENT CURBS, ETC. 11

2.12 FLASHING - GRAVEL STOPS OR ROOF EDGE METALS 12

2.13 MEMBRANE REPAIR 13

2.14 TEMPORARY CLOSURE 13

2.15 ACRYLITOP PC-100 COATING 13

2.16 ROOF WALKWAYS 14

2.17 SHEET METAL WORK 15

2.01 GENERAL

This section of Firestone's Technical Manual provides instructions for the installation of Firestone's RubberGard R.M.A. System. Reference to the Design Guide, Technical Information Sheets (T.I.S.), and other sections of Firestone's Technical Specifications is necessary to ensure that the finished roof system is installed in compliance with Firestone requirements.

15, 20, and 25 year warranties and wind warranties in excess of 55 mph, may require special considerations with regards to fasteners, plates, insulations, membrane gauge, and attachment requirements. Refer to the System Design Guide of this Technical Database for specific requirements.

NOTE: IF A PROPOSED APPLICATION FALLS OUTSIDE OF THIS SPECIFICATION, CONTACT FIRESTONE TECHNICAL SERVICES FOR ADDITIONAL INFORMATION.

2.02 JOB SITE CONSIDERATIONS (CAUTION AND WARNINGS)

A. SAFETY:

1. Comply with all applicable regulatory safety regulations.
2. Keep all adhesives, sealants and cleaning materials away from ALL ignition sources (i.e., flames, fire, sparks, etc.). Do not smoke while using these materials.
3. Consult container labels, Material Safety Data Sheets and Technical Information Sheets for specific safety instructions for all products used on the project.
4. Care must be used when installing fasteners to avoid possible conduits and other piping in and under the deck.
5. Fumes from adhesive solvents may be drawn into the building during installation through rooftop intakes. Refer to Firestone's Technical Information Sheet "Recommended Guidelines for Application of Roofing Materials to an Occupied Building".
6. Do not use heat guns or open flames to dry adhesives and primers.

B. CAUTIONS:

1. Store Firestone RubberGard EPDM membranes in the original undisturbed plastic wrap in a manner to protect it from becoming damaged. Insulation must be properly stored and protected from ignition sources, moisture and damage. Consult container labels, Material Safety Data Sheets and Technical Information Sheets for specific safety, use and storage instructions for all products used on the project.
2. Do not use oil-base or bituminous-base roof cement with Firestone RubberGard EPDM membrane.
3. Store Firestone Insulations properly protected from ignition sources, moisture and damage.

C. COLD WEATHER:

1. When the outside temperature is below 40 °F (4.4 °C), certain combinations of temperature and humidity may cause condensation on the surface of solvent-based adhesives and primers. If this condition occurs, discontinue the application. When the ambient air conditions no longer cause condensation on adhesive surfaces and the membrane is clean and dry then re-apply additional adhesive or primer and proceed.
2. The consistency of sealants, adhesives and primers will begin to thicken as the temperature drops. To minimize this, the following is recommended:
 - a) Start work with sealants, adhesives and primers that have been stored between 60° F and 80° F (15.5° C and 26.7° C). Insulated and heated boxes

may be helpful.

- b) Complete test areas to determine if conditions will cause problems such as condensation with the application of the material.
 - c) Stop the operation or change to another warm container when material becomes too thick to properly apply.
3. Do not use heat guns or open flames to dry adhesives and primers.
 4. When the outside temperature is below 40° F (4.4° C), installation of the Firestone RubberGard EPDM System requires additional application procedures:
Ensure that the roof surface is dry. Moisture may cause poor adhesion, and may lead to moisture entrapment within the roofing system.
Use of temporary roofs should be considered when roof applications must occur in cold or potentially wet weather to permit continued interior construction or roof- top work to proceed.
 5. If using Water-Based Bonding Adhesive (WBBA), temperatures and substrate must be at least 40 °F (4.4 °C) and rising for the material to be applied and perform as designed. Longer drying times should be expected for lower temperatures and higher humidity.

2.03 ROOF SUBSTRATE PREPARATION



Diagram 2.03-1

A. CORRECT SUBSTRATE DEFECTS:

1. Defects that need to be corrected before work can commence should be brought to the attention of the General Contractor or Owner in writing and addressed by them.
2. For re-roofing applications, remove existing roof system components as specified by the project designer. If components are discovered during installation that could be detrimental to the performance of the new roof system, they should be brought to the attention of the project designer for corrective action.
3. If soundness and integrity of the existing roof system cannot be verified, good roofing practice requires a complete tear-off to the structural deck. However, recovering an existing roof system is an alternative to removing existing roof components. Non-destructive testing, in conjunction with core cuts, must be completed to determine the condition of the existing roof system and decking.
4. The building owner or project designer is responsible for assuring that all wet insulation and/or wet substrate materials are removed in a re-roofing application. The best diagnostic technique is taking and evaluating a series of roof cuts. There

are three other techniques that are currently available to make this determination by indirect means: These are:

- nuclear moisture detection
- infrared thermography
- electric capacitance

These techniques provide measurement of factors that can be associated with the presence of moisture, which can then be verified with the use of roof core cuts to confirm the results of the non-destructive testing.

5. In the absence of a design professional, the roofer should coordinate with the building owner to assure conditions are satisfactory to commence with the project as designed.

B. REMOVE MOISTURE:

1. Ponded water, snow, frost and/or ice, present in more than trace amounts must be removed from the work surface(s) prior to installing the RubberGard EPDM Roofing System.

C. PREPARE SURFACE:

1. Acceptable substrates to which the RubberGard EPDM Roofing System is installed must be properly prepared prior to roof system installation. The surface must be relatively even, clean, dry, smooth, free of sharp edges, fins, loose or foreign materials, oil, grease and other materials that may damage the roof system. Rough surfaces that could cause damage to the membrane must be overlaid with insulation.

D. FILL VOIDS:

1. All surface voids of the immediate membrane substrate greater than 1/4" (6.35 mm) wide must be filled with insulation.

2.04 WOOD NAILER LOCATION AND INSTALLATION

Wood nailers must be installed as specified by the project designer or as noted in Firestone Details and the EPDM System Design Guide. Install wood nailers as follows: Firestone Building Products no longer requires the use of treated wood nailers. This is due to the new EPA requirements that have caused treated lumber to have more corrosive properties than the previous generation of wood treatments. See Technical Bulletin dated March 3, 2005.

If architectural specifications require the use of treated wood nailers, the following Firestone requirements apply:

- Refer to the Firestone Design Guide for the appropriate Firestone fastener to be used for securing membrane into wood nailers.
- Nails penetrating treated wood nailers must be hot-dipped galvanized, meeting ASTM A653, Class G185 or as currently recommended by industry associations.
- Aluminum fasteners, flashings and accessory products must not make direct contact with treated wood nailers.
- Uncoated metal and painted metal flashing and accessories, except for 300-series stainless steel, must not make direct contact with treated wood nailers.
- When in doubt of the type of treatment of the wood nailer or its compatibility with a metal component, use EPDM membrane as a separator.

Because of recent EPA regulations regarding treated wood, new treatments for lumber may be highly corrosive to fasteners. Contact the fastener manufacturer for their recommendations on fasteners if attaching nailers that have been treated with corrosive materials.

A. WOOD NAILER GRADE:

1. When wood nailers are used, Firestone specifications require the use of wood that is kiln-dried (Southern Pine, Douglas Fir) structural grade #2 or better, unless otherwise noted. While being stored on the roof, properly elevate and cover non-treated wood to protect from the weather and keep dry. Nailers must be properly anchored to provide secure attachment through the warranty term. Nailers are not covered by the Firestone warranty.

B. SIZE OF NAILER

1. Nailers shall be a minimum thickness of 2" x 4" nominal (1-1/2" (37.1mm) x 3-1/2" (89mm)) and exceed the width of any metal flange attached to it by a minimum of 1/2" (12.7mm).

C. POSITION WOOD NAILER

1. Total wood nailer height must match the total thickness of insulation being used and should be installed with a 1/8" (3.2 mm) gap between each length and each change of direction. When more than one nailer thickness is used end joints should be staggered a minimum of 12" from the prior layer in straight runs.

D. SECURE WOOD NAILER

1. Wood nailers must be firmly fastened to the deck or building. Mechanically fasten wood nailers to resist a minimum force of 200 lb/f (890 N) in any direction. Defer to attachment requirements of the roofing system as specified by the project designer if greater than 200 lbf (890 N).

E. TAPER WOOD NAILER

1. The wood nailer must be tapered (if applicable) so that it will always be flush at the point of contact with the insulation (refer to Firestone Details).

F. POURED-IN-PLACE DECKS

1. For new construction over poured-in-place decks or fill, and all recover projects, a waterproof separator membrane shall be placed between the non-treated lumber and the deck.

G. INSTALLATION OF WOOD NAILERS BY OTHERS

1. Make these specifications and details available when nailers are to be installed by others. Work that compromises the integrity of the roof system may jeopardize the roof warranty.

H. FOR ADDITIONAL INFORMATION

1. Please consult the NRCA Special Report, "Use of Treated Wood in Roof Assemblies."

2.05 AIR OR VAPOR BARRIER INSTALLATION

A. INSTALL VAPOR RETARDER (WHEN SPECIFIED):

1. Install a vapor retarder as specified by the project designer or as required by Firestone.

B. INSTALL AIR BARRIER (WHEN SPECIFIED)

1. Install an air barrier as specified by the project designer or as required by Firestone.

2.06 INSULATION INSTALLATION

A. Install Insulation:

Install only as much insulation as can be covered with roofing membrane and completed before the end of the day's work or before the onset of inclement weather.

B. Fill Voids Between Standing Seams:

Areas between standing seams must be filled with Firestone ISO 95+ in order to create a solid substrate, flush with the standing seam tops, to support the subsequent layers of insulation.

C. Fit Insulation:

Neatly fit insulation to all penetrations, projections, and nailers. Insulation should be loosely fitted, with gaps greater than 1/4" (6.3 mm) filled with acceptable insulation. Under no circumstances should the membrane be left unsupported over a space greater than 1/4" (6.3 mm). Tapered insulation with acceptable facers for bonding must be installed around roof drains so as to provide proper slope for drainage as shown in Firestone Details.

D. Stagger Insulation Joints:

When installing multiple layers of insulation, all joints between layers should be staggered but is not required for the issuance of a Firestone Warranty.

E. Insulation Attachment

Insulation must be attached using Firestone fasteners and insulation plates. Refer to the Technical Information Sheet for the specific insulation being used for attachment patterns and fastening rates. When installing a multi-layer insulation assembly, the fastening pattern is determined by the type and thickness of the top layer of insulation.

2.07 MEMBRANE SECUREMENT AND INSTALLATION (QSRMA ATTACHMENT)

- A. Install the QuickSeam R.M.A. Strip:** Mechanically Attach the QuickSeam R.M.A. strips to the substrate with an approved fastener and a Firestone "V" plate or Batten Bar per Firestone specifications. Do not remove release paper until Single-Ply QuickPrime Primer is applied and membrane is ready for installation. Should a batten bar be used, it is required to caulk the fastener heads with AP Sealant and round the corners prior to installation.

Note: Precaution should be taken to ensure that the R.M.A. strips are installed perpendicular to the steel deck.

- B. Position the EPDM Sheets:** Place membrane panel, without stretching, over the installed QSRMA Strip and allow to relax for a minimum of 30 minutes before splicing or attaching. During cold weather application, it is recommended that the smallest panels be used to minimize folds. (Larger panels have factory folds which may take longer to relax during cold weather). The RubberGard R.M.A. System must be installed so that the seams shed the flow of water.

After making sure the sheet is placed in its final position allowing for the minimum lap width per Firestone specifications, fold it back evenly onto itself without wrinkles to expose the underside mating surface of the sheet, exposing the underside of the membrane and the QSRMA Strip.

Note: It will assist in the application if area of the membrane that will be mated to the QSRMA Strip is marked as the membrane is folded back.

- C. Apply Single-Ply QuickPrime Primer:** Apply Single-Ply QuickPrime Primer using the QuickScrubber to the back of the EPDM membrane over the width of the QuickSeam R.M.A. strip. Ensure that the primer has been applied to a sufficient

width and with sufficient quantity.



D. Remove the paper backing: Allow the Single-Ply QuickPrime Primer to flash off completely. Use the touch-push test to test for dryness. Remove both release papers from the QuickSeam R.M.A. strip and roll the field membrane onto the strip. Use a Stiff Push Broom to ensure an initial bond between the RMA Strip and the field membrane.



E. Roll the QuickSeam R.M.A. Strip: Using a stiff broom Roll the strips using Firestone's QuickRoller across its entire length above both tapes.

Note: Do not use metal rollers or power rollers over the QSRMA Strip.

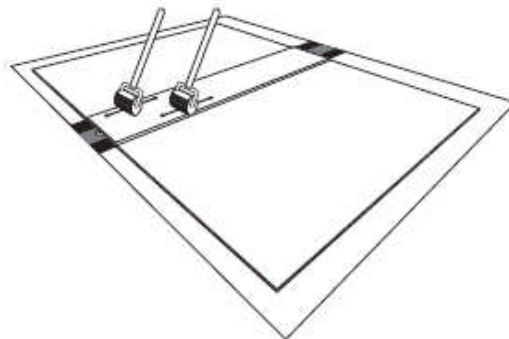

2.08 MEMBRANE SEAMING

A. Position and Fold Back the Lap Edge:

Position the membrane at the seam area by overlapping membrane 4" (102 mm) for 3" (76 mm) QuickSeam Tape and 8" (203mm) for 7" (178 mm) QuickSeam Tape. Once the membrane is in place, mark the bottom membrane 1/2" (12.7 mm) to 3/4" (19 mm) from the edge of the top membrane every 4' (1.2 m) to 6' (1.8 m) using the marking crayon provided with the QuickSeam Tape. Tack the membrane back with Single-Ply QuickPrime Primer as necessary to hold back the membrane at the splicing area.

B. Apply Single-Ply QuickPrime Primer to Seam Area:

Remove excess amounts of dusting agent on the membrane and at factory splices using a stiff push broom. Stir Single-Ply QuickPrime Primer thoroughly before and during use. Dip the QuickScrubber into the bucket of Single-Ply QuickPrime Primer, keeping the pad flat. Apply the Single-Ply QuickPrime Primer using long back and forth type strokes with pressure along the length of the splicing area until surfaces become a dark gray in color. Apply Single-Ply QuickPrime Primer to both surfaces at the same time. Change the scrub pad every 200 feet (61 m) of seam or when the pad will no longer hold the proper amount of Single-Ply QuickPrime Primer. Additional scrubbing is required at all factory seams and at areas that may have become contaminated or have excess amounts of dusting agent.

C. Apply the QuickSeam Splice Tape:

After allowing the Single-Ply QuickPrime Primer to dry properly using the Touch-Push Test, apply the QuickSeam Seam Tape to the bottom membrane, aligning the edge of the release paper with the markings. Immediately roll the splice tape with a 3" - 4" (76 mm - 102 mm) wide silicone hand roller, a short nap 3" (76 mm) paint roller, or a clean QuickScrubber or QuickScrubber Plus pad and handle.

D. Check the Splice Tape Alignment:

When the QuickSeam Splice Tape has been installed for the entire seam length, position the top membrane to rest on top of the tape's release paper backing. Trim the top panel as necessary to assure that 1/8" - 1/2" (3.1mm -12.7 mm) of the QuickSeam Seam Tape will be exposed on the finished seam.

E. Remove Release Paper Backing:

To remove the paper backing from the tape, roll back the EPDM membrane and peel the release paper backing off the QuickSeam Splice Tape by pulling against the weight of the bottom panel at approximately a 45° angle to the tape and parallel with the roof surface. Allow the top membrane to fall freely onto the exposed QuickSeam Splice Tape. Broom the entire length of the seam at a 45° angle as the release paper is being removed.

F. Roll the Seam:

Roll the seam using a 1-1/2" - 2" (38 mm - 51 mm) wide silicone hand roller or the Firestone QuickRoller first across the seam and then along the entire length of the seam.

G. Special Considerations (End Laps, "T" Joints, etc.):

1. End Laps:

When the seam is greater in length than the tape, the adjoining QuickSeam Splice Tape must be overlapped a minimum of 1" (25.4 mm).

2. Trim QuickSeam Splice Tape at "T" Joints:

Trim QuickSeam Splice Tape so that the edge of QuickSeam Splice Tape and the edge of the membrane are flush beneath the "T" Joint area.

3. "T" Joints:

Apply a section of Firestone QuickSeam Flashing or QuickSeam Joint Cover over the "T" joint area.

4. Using QuickSeam Splice Tape with Cured EPDM as Flashing:

If cured EPDM is used as flashing, apply an 8" (203 mm) long section of QuickSeam Flashing or a QuickSeam Joint Cover over the intersection of the flashing and field Seams.

2.09 ADDITIONAL MEMBRANE SECUREMENT AND BASE TIE-IN FLASHING

Secure the membrane (base tie-in) at all locations where the membrane goes through an angle change greater than 1" (25.4 mm) in 12" (305 mm) (i.e., roof edges, curbs, interior walls, etc.)

- A.** Attach the QSRPF Strip to the penetration, parapet wall or deck using Firestone 2" (51 mm) Seam Plates, V-Plates or Firestone Batten Strips fastened a maximum of 12"(305 mm) o.c. Roll the membrane into place and then fold back, exposing the underside of the membrane and the QSRPF Strip. When using batten strips, apply Firestone AP Sealant over each fastener head, assuring that the fastener head is completely covered.
- B.** Apply Single-Ply QuickPrime Primer to the membrane where it will mate with the QuickSeam Splice Tape and allow to dry.
- C.** Apply Firestone Bonding Adhesive to the back half of the QSRPF, to the membrane that is to be bonded to the penetration or wall, and to the penetration or wall itself.
- D.** After the surfaces have dried properly as determined by using the Touch-Push Test, remove the release paper from the QuickSeam Reinforced Perimeter Fastening Strip and roll the membrane into place, assuring a tight fit into the transition between the horizontal and vertical surfaces. Continue to roll the membrane up the wall and broom in place with a stiff push broom. Roll the membrane over the QuickSeam Tape with a 1-1/2"- 2" (38 mm x 51 mm) wide silicone roller or Firestone QuickRoller across the tape and then along its length.
- E.** Complete vertical laps seams as described in the lap splice section of this specification. Install a T-Joint Cover over any vertical lap splices that go through an angle change (Refer to Firestone Details).

2.10 FLASHING - PENETRATIONS

A. General:

- 1. Remove all loose existing flashing (i.e., lead, bituminous materials, mastic, etc.).
- 2. Flash all penetrations passing through the membrane.

B. The flashing seal must be made directly to the penetration. Pipes, Round Supports, Structural Steel Tubing, etc.:

- 1. Flash penetrations with Firestone EPDM Pre-Molded Pipe Flashings wherever possible. Do not cut or patch EPDM Pre-Molded Pipe Flashings to assist in their installation.
- 2. Flash penetrations using FormFlash when the use of Pre-Molded EPDM Pipe Flashings is not possible.
- 3. Refer to Firestone's Technical Information Sheet for minimum and maximum pipe diameters that can be successfully flashed with Pre-Molded EPDM Pipe Flashings, Structural Steel Tubing: Use a field-fabricated pipe flashing detail when the corner radius is greater than 1/4" (6.35 mm) and the longest side of the tube does not exceed 12" (305 mm). When the tube exceeds 12" (305

mm) use a standard curb detail including base tie-in and suitable termination.

C. Roof Drains:

These specifications apply for installation of cast iron drains only. For all other drain types contact Firestone Technical Services.

1. Remove existing clamping ring. Remove any broken clamping hardware and replace.
2. Remove all existing flashing (including lead flashing), roofing materials and cement from the existing drain in preparation for membrane and Water Block Seal.
3. Provide a clean even finish on the mating surfaces between the clamping ring and the drain bowl. Install tapered insulation with suitable bonding surfaces around the drain to provide a smooth transition from the roof surface to the drain. Slope into drain cannot be greater than 1" in 12" (25.4 mm in 305 mm).
4. Position the membrane and cut a hole for the roof drain allowing a 1/2" (12.7 mm) to 3/4" (19.1 mm) of membrane inside the clamping ring.
5. Make round holes in the membrane to align with clamping bolts (a paper punch may be used). Do not cut the membrane back to the bolt holes.
6. Install Firestone Water Block Seal on the clamping ring seat flange below the membrane. Use a minimum of one half of a 10 oz. (295 cc) tube for a 10" (254 mm) drain.
7. Install the roof drain clamping ring and all clamping bolts. Tighten the clamping bolts to achieve constant compression.

D. Pipe Clusters and Unusual Shaped Penetrations:

1. Fabricate penetration pockets to allow a minimum clearance of 1" (25.4 mm) between the penetration(s) and all sides.
2. Secure penetration pockets and flash per Firestone Details.
3. Fill penetration pockets with Firestone Pourable Sealer and mound to shed water. Pourable Sealer must be a minimum of 2" (51 mm) deep and 1" (25.4 mm) thick around the penetrations.

E. Hot Pipes:

Protect the RubberGard EPDM components from direct contact with steam or heat sources when the in-service temperature is in excess of 140° F (60° C). In all such cases flash to an intermediate "cool" sleeve.

F. Flexible Penetrations

Provide a weathertight gooseneck set in Water Block Seal and secured to the deck. Flash in accordance with Firestone Details.

G. Scuppers:

1. Provide and install a new welded watertight sleeve.
2. Set welded watertight scupper in Water Block Seal and secure scupper to the structure.
3. Flash in accordance with Firestone Details.

H. Expansion Joints:

Install where specified by the project designer. Install expansion joints in accordance with Firestone details.

2.11 FLASHING - WALLS, PARAPETS, MECHANICAL EQUIPMENT CURBS, ETC.

A. General:

Using the largest pieces of continuous RubberGard EPDM membrane practical, flash all walls, parapets, curbs, etc., to the height as specified by the project designer.

B. Evaluate Substrate:

See chart in the System Design Guide section of this manual.

C. Install Additional Membrane Securement at Curbs, Penetrations, Walls, etc.:

Refer to Section 2.09 of this specification.

D. Provide Termination:

Provide termination directly to the vertical substrate as shown in Firestone Details.

E. Provide Intermediate Attachment:

Intermediate attachment of membrane is required at 36" (914 mm) intervals in accordance with Firestone Details unless:

1. The wall surface is smooth without noticeable high spots or depressions (i.e., plywood, poured or precast concrete, or hollow core block or masonry walls where joints are flush with masonry surface)
2. The termination is either a Termination Bar or membrane has been installed underneath a coping to the outside edge of the wall.

2.12 FLASHING - GRAVEL STOPS OR ROOF EDGE METALS

A. Flash Gravel Stops or Roof Edge Metals using Firestone QuickSeam Flashing:

1. Clean the Membrane and Metal Edge:

Remove excess amounts of dusting agent by brooming. Apply Single-Ply QuickPrime Primer to the metal edging and membrane as described in Firestone Specifications. Allow the Single-Ply QuickPrime Primer to flash-off.

2. Apply QuickSeam Flashing:

Place the roll of QuickSeam Flashing on the roof a few feet ahead of the application starting point, positioned so that it unrolls from the top of the roll (release paper will be on top). Remove approximately 2' - 3' (.6 m - .9 m) of release paper and apply to the metal flange and RubberGard Membrane. Lap adjacent rolls of QuickSeam Flashing a minimum of 1" (25.4 mm).

3. Roll the QuickSeam Flashing:

With a 1-1/2" - 2" (38 mm - 51 mm) wide silicone hand roller, roll the QuickSeam Flashing to assure proper adhesion. Additional attention must be given to factory seam intersections and to any change in plane.

4. Special Considerations (End Laps, "T" Joints, etc.):

- a. Apply 6" (152.4 mm) length of QuickSeam Flashing, a QuickSeam Joint Cover or 6" x 6" (152.4 mm x 152.4 mm) FormFlash to the inside edge of the QuickSeam Flashing at all overlaps (Refer to Details).
- b. Apply 6" (152.4 mm) length of QuickSeam Flashing, a QuickSeam Joint Cover or 6"x 6" (152.4 mm x 152.4 mm) FormFlash at all intersections between the QuickSeam Flashing and field-fabricated seams (Refer to Details).
- c. If the roof edge includes a gravel stop and sealant is not applied between the laps in the metal edging, an additional piece of QuickSeam Flashing must be applied over the metal lap to the top of the gravel stop, after the initial application of QuickSeam Flashing. Seam Edge Treatment shall be applied at the intersections of the two flashing sections.

B. Optimal Application:

1. The optimal use of QuickSeam Flashing is where a 3" (76 mm) metal flange is being used. This will provide the minimum 2" (51 mm) seam to the RubberGard Membrane, with the remaining 3" (76 mm) of the material completely covering the metal flange.
2. If a flange wider than 3" (76 mm) is used, the joints of the sheet metal edge must be flashed using QuickSeam Flashing and Single-Ply QuickPrime Primer. In addition, it is recommended that 3" (76 mm) QuickSeam Splice Tape be placed in the sheet metal laps to help seal the metal edge.

C. Special Considerations for Copper Edging:

Copper may be weathered or coated with an anti-tarnish lacquer which makes adhesion difficult. Therefore, cleaning techniques must be used to prepare the copper surface to receive the QuickSeam Flashing. Firestone requires that the copper be scrubbed with acetone or lacquer thinner, using clean cotton cloths. Cleaning before installation is recommended, however, cleaning can take place after metal is attached if care is taken not to allow the solvents to come into contact with the membrane. After the cleaner dries, apply Single-Ply QuickPrime Primer and QuickSeam Flashing per Firestone Specifications.

2.13 MEMBRANE REPAIR

A. Repair Cuts/Punctures in the Membrane, or Wrinkles Within 18" (458 mm) of a Seam:

1. A wrinkle running toward a seam or within 18" (458 mm) of a seam must be repaired. The wrinkle must be cut out so that the membrane lays flat, and patched with a piece of EPDM membrane having no factory seams that extends a minimum of 3" (76 mm) beyond the boundaries of the cut in all directions. If the wrinkle occurs through QuickSeam Flashing or QuickSeam FormFlash, then like material must be used for repair however, QuickSeam Flashing or QuickSeam FormFlash may not extend onto the roof surface more than 6" (152 mm).
If repairing of the same wrinkle must continue, then EPDM membrane must be used. Install the EPDM repair membrane first, and round all corners of the repair piece.

QUICKSEAM FLASHING OR QUICKSEAM FORMFLASH CANNOT BE USED TO REPAIR CURED MEMBRANE.

2. Repair a cut or puncture in the EPDM membrane with EPDM membrane. The repair must extend a minimum of 3" (76 mm) beyond the boundary of the affected area in all directions. Round all corners of the repair piece (Example: a pinhole will require a minimum 6"x 6" (152 mm x 152 mm) EPDM section).

B. Clean the Membrane:

When repairing membrane which has been in service for some time, it is necessary to remove accumulated dirt. Proper membrane preparation is made by scrubbing the membrane with a scrub brush and warm soapy water, rinsing with clear water and drying with clean cotton cloths. Clean the area using clean cotton cloths with Firestone Splice Wash. Additional cleaning using Firestone Splice Wash is often necessary.

C. Install Repair Material:

Repairs must be made with SA-1065 Splice Adhesive. Refer to the Flashing Seam Details of this manual for application requirements of Splice Adhesive.

2.14 TEMPORARY CLOSURE

Temporary closures which assure that moisture does not damage any completed section of the new roofing system are the responsibility of the licensed applicator. It is not warrantable by Firestone. Completion of flashings, terminations and temporary closures must be completed as required to provide a watertight condition.

See the Firestone V-Force Membrane Technical Information Sheet for further information.

2.15 ACRYLITOP PC-100 COATING

AcryliTop PC-100 can be applied to the RubberGard membrane or flashing to offer a reflective surface, and add to its service life. In addition, AcryliTop PC-100 can be

applied to existing RubberGard EPDM roofs under warranty helping extend the membrane life. Should the coating of an existing roof be considered, the roof system should first be inspected by a Firestone licensed contractor to assure that the system itself is not in need of repair prior to applying AcryliTop PC-100. Refer to the Technical Information Sheet and Material Safety Data Sheets for AcryliTopPC-100 and Membrane PreWash for additional information on application, storage and safety.

A. Clean membrane surface:

Before applying the AcryliTop PC-100, the RubberGard membrane must be cleaned using Firestone's Membrane PreWash. Clean the roof of debris, as needed, with a broom or leaf air blower. Remove any leaves or large pieces of debris, such as stones, branches, etc. Apply Membrane PreWash at a rate of 300-500 square feet of membrane surface using a 2-3 gallon agricultural tank sprayer and allow to dry for 5-10 minutes (application rates may vary depending on the cleanliness of the membrane). Assure that tank sprayer has a pressure relief valve. Do not allow PreWash to come in contact with other surfaces. Using a 3000-4000 psi pressure washer that provides a minimum 4 gallons per minute, remove the PreWash working first away from the drains or gutters, then back towards them. A 40° fan spray nozzle for pressure washing should be used. Should deposits of dirt and dusting agent remain, additional cleaning with the pressure washer is required. (Caution: Do not allow the spray wand to be closer than 12 inches from the membrane to prevent damage).

B. Apply AcryliTop PC-100 Base Coat (Only when using a roller application):

After the membrane has dried, apply Firestone AcryliTop PC-100 Base Coat at a rate of approximately 200 square feet per gallon using a 3/8" nap paint roller. At this rate, membrane may be slightly visible through the base coat. Allow Base Coat to dry thoroughly before applying the AcryliTop PC-100 top coat.

C. Apply AcryliTop PC-100:

1. ROLLER APPLICATION:

Using a 3/8" nap paint roller, apply the AcryliTop PC-100 coating a 90° angle to the AcryliTop PC-100 Base Coat at a rate of approximately 200 square feet per gallon or as necessary to assure complete coverage of the AcryliTop PC-100 Base Coat. The finished dry mil thickness shall be a minimum of 10 mils total.

2. SPRAYER APPLICATION:

Over the properly cleaned membrane, apply AcryliTop PC-100 at a rate of approximately 100 square feet per gallon, resulting in a minimum 10 mil dry film thickness. The sprayer used for application of the AcryliTop PC-100 shall be a 30:1 ratio pump using a pressure of 90-100 psi at a rate of 125 cubic feet per minute.

2.16 ROOF WALKWAYS

A. Lay Out Firestone RubberGard QuickSeam Walkway Pads:

1. Install walkway pads in locations as specified by the project designer and in accordance with the System Design Guide Section of this Manual. Layout Firestone RubberGard QuickSeam Walkway Pads so that the flat surface is over the completed RubberGard QuickSeam Membrane, spacing each pad a minimum of 1" (25.4 mm) and a maximum of 3" (76 mm) from each other to allow for drainage.
2. If Firestone RubberGard Walkway Pads must be installed over field-fabricated seams or within 6" (152 mm) of a seam edge, install QuickSeam Flashing over the seam edge. The QuickSeam Flashing must extend beyond the walkway pad a minimum of 6" (152 mm) on either side.

B. Attach Firestone RubberGard QuickSeam Walkway Pads to the Membrane:

1. Clean the Membrane:
Clean the membrane using Firestone Single-Ply QuickPrime Primer where the

- QuickSeam Splice Tape will contact the membrane.
- 2. Place Walkpad:**
Remove the release paper from the QuickSeam Splice Tape. Turn the walkpad over and place it in the Single-Ply QuickPrime Primer.
 - 3. Apply Pressure:**
Walk on the pad to press in place assuring proper adhesion.

2.17 SHEET METAL WORK

- A.** For specific installation instructions for Firestone Sheet Metal, refer to the System Design Guide and Technical Information Section of this manual.
- B.** For sheet metal work not supplied by Firestone, refer to fabrication and installation requirements specified by the project designer as well as industry standards.

END OF SECTION